

# MODEL 3000, 3100, 3200 GRAVITY DAMPERS & ACCESSORIES

		W I D T H												
Inches	12	16	20	24	28	32	36	40	44	48	52	56	60	
H E I G H T	12	\$79.31	\$88.58	\$101.97	\$121.54	\$131.84	\$157.59	\$170.98	\$190.55	\$206.00	\$220.42	\$218.36	\$234.84	\$256.47
	16	\$91.67	\$106.09	\$120.51	\$144.20	\$151.41	\$179.22	\$196.73	\$214.24	\$233.81	\$297.67	\$244.11	\$261.62	\$340.93
	20	\$106.09	\$122.57	\$135.96	\$162.74	\$176.13	\$201.88	\$217.33	\$238.96	\$309.00	\$330.63	\$327.54	\$347.11	\$374.92
	24	\$112.27	\$129.78	\$143.17	\$173.04	\$185.40	\$213.21	\$272.95	\$297.67	\$323.42	\$349.17	\$370.80	\$388.31	\$416.12
	28	\$126.69	\$143.17	\$160.68	\$188.49	\$206.00	\$232.78	\$297.67	\$323.42	\$349.17	\$370.80	\$388.31	\$416.12	
	32	\$149.35	\$167.89	\$187.46	\$220.42	\$235.87	\$263.68	\$337.84	\$364.62	\$390.37	\$415.09	\$406.85	\$433.63	\$460.41
	36	\$187.46	\$209.09	\$223.51	\$263.68	\$283.25	\$312.09	\$390.37	\$418.18	\$444.96	\$471.74	\$460.41	\$489.25	\$520.15
	40	\$211.15	\$231.75	\$252.35	\$294.58	\$312.09	\$345.05	\$426.42	\$459.38	\$485.13	\$511.91	\$502.64	\$530.45	\$561.35
	44	\$231.75	\$252.35	\$276.04	\$320.33	\$341.96	\$374.92	\$459.38	\$492.34	\$525.30	\$552.08	\$540.75	\$567.53	\$602.55
	48	\$247.20	\$271.92	\$297.67	\$341.96	\$364.62	\$401.70	\$492.34	\$530.45	\$559.29	\$587.10	\$574.74	\$605.64	\$640.66
	52	\$264.71	\$288.40	\$312.09	\$364.62	\$390.37	\$426.42	\$522.21	\$559.29	\$591.22	\$684.95	\$670.53	\$704.52	\$746.75
56	\$285.31	\$312.09	\$336.81	\$393.46	\$418.18	\$455.26	\$548.99	\$596.37	\$631.39	\$728.21	\$711.73	\$749.84	\$792.07	
60	\$310.03	\$340.93	\$366.68	\$423.33	\$452.17	\$492.34	\$609.76	\$636.54	\$672.59	\$776.62	\$760.14	\$799.28	\$841.51	

## NOTES:

- For dimensions not shown in table, use price for next larger dimension.  
(eg. 17" w x 13" h, use 20" w x 16" h for price)
- Minimum size available is 8" x 8".



## OPTIONAL ACCESSORIES

ITEM	LIST PRICE
Bird Screen Factory Installed	\$6.00/Sq. Ft. Minimum \$49.44
Insect Screen Factory Installed	\$9.00/Sq. Ft. Minimum \$74.16
Chain Operator (5 feet of chain)	\$43.26

## ORDERING METHOD FOR BACKDRAFT & MOTORIZED BACKDRAFT DAMPERS

S R 32 16 X 16

- Height 1/4" increments
- Separator
- Width 1/4" increments
- Series 30 for 3000, 31 for 3100 or 32 for 3200
- Non motorized - blade type
- Motorized - motor
- Shutter

- R - for Roll form (fans using under 1 HP motors)
- E - for Extruded (heavier blades for motors above 1 HP)
- X - for 115/230V *Extruded blades with multi products motor is standard*
- Z - for 24V AC

## MODEL 3000M, 3100M, 3200M MOTORIZED DAMPERS & ACCESSORIES

		W I D T H												
Inches	12	16	20	24	28	32	36	40	44	48	52	56	60	
H E I G H T	12	\$245.00	\$261.00	\$280.00	\$291.00	\$307.00	\$334.00	\$375.00	\$406.00	\$430.00	\$439.00	\$462.00	\$490.00	\$520.00
	16	\$256.00	\$269.00	\$289.00	\$300.00	\$317.00	\$342.00	\$417.00	\$427.00	\$438.00	\$469.00	\$494.00	\$520.00	\$551.00
	20	\$267.00	\$280.00	\$302.00	\$311.00	\$328.00	\$357.00	\$429.00	\$432.00	\$451.00	\$479.00	\$503.00	\$533.00	\$563.00
	24	\$280.00	\$297.00	\$316.00	\$325.00	\$342.00	\$368.00	\$455.00	\$457.00	\$463.00	\$491.00	\$516.00	\$544.00	\$573.00
	28	\$289.00	\$307.00	\$382.00	\$384.00	\$404.00	\$433.00	\$487.00	\$500.00	\$504.00	\$523.00	\$526.00	\$553.00	\$584.00
	32	\$305.00	\$319.00	\$407.00	\$397.00	\$437.00	\$469.00	\$513.00	\$517.00	\$531.00	\$541.00	\$555.00	\$581.00	\$622.00
	36	\$316.00	\$358.00	\$412.00	\$414.00	\$454.00	\$485.00	\$527.00	\$581.00	\$606.00	\$614.00	\$627.00	\$659.00	\$748.00
	40	\$358.00	\$415.00	\$438.00	\$448.00	\$469.00	\$537.00	\$586.00	\$596.00	\$611.00	\$645.00	\$673.00	\$725.00	\$842.00
	44	\$387.00	\$428.00	\$453.00	\$460.00	\$611.00	\$592.00	\$609.00	\$617.00	\$622.00	\$655.00	\$726.00	\$826.00	\$924.00
	48	\$407.00	\$450.00	\$477.00	\$485.00	\$587.00	\$614.00	\$639.00	\$654.00	\$668.00	\$686.00	\$827.00	\$857.00	\$947.00
	52	\$414.00	\$464.00	\$488.00	\$585.00	\$600.00	\$624.00	\$641.00	\$666.00	\$698.00	\$836.00	\$826.00	\$924.00	\$960.00
56	\$439.00	\$477.00	\$502.00	\$580.00	\$614.00	\$637.00	\$664.00	\$679.00	\$781.00	\$875.00	\$842.00	\$947.00	\$975.00	
60	\$452.00	\$492.00	\$600.00	\$614.00	\$620.00	\$654.00	\$710.00	\$828.00	\$857.00	\$892.00	\$924.00	\$960.00	\$992.00	

## NOTES:

- For dimensions not shown in table, use price for next larger dimension.  
(eg. 17" w x 13" h, use 20" w x 16" h for price)
- Minimum size available is 8" x 8".

Motorized shutters up to 60" x 60" use one motor.



## OPTIONAL ACCESSORIES

ITEM	LIST PRICE
End Switch Factory Installed	\$194.67
Bird Screen Factory Installed	\$6.00/Sq. Ft. Minimum \$49.44
Insect Screen Factory Installed (Includes sleeve)	\$9.00/Linear Ft. Minimum \$190.55
Belimo Actuators Available	SEE PAGE 34

## REPLACEMENT MOTORS

REPLACEMENT MOTORS	LIST PRICE
2W100-115/230 Maximum 8 square feet per motor 115/230V AC	\$173.04
2W104 Maximum 8 square feet per motor 24V AC	\$173.04



Non-standard shutters are non-returnable and cannot be cancelled.  
Please confirm your measurements and identify the series, width, height and blade type correctly.

# CONTROLS / OPERATORS

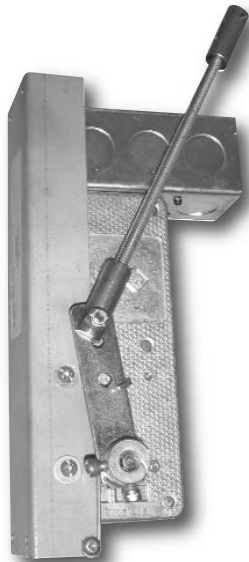

**MULTI PRODUCTS**



**BELIMO ACTUATORS**

MANUFACTURER	MODEL	DESCRIPTION	MAX DAMPER (SQ. FT.)		VOLTAGE	LIST PRICE
			WITH SEALS	NO SEALS		
CHAIN OPERATOR	CHAIN OP	Manual Open, Manual Close	N.A.	N.A.	N.A.	\$41.20
LOCKING QUADRANT	2V100	Manual Open, Manual Close	N.A.	N.A.	N.A.	\$39.14
MULTI PRODUCTS	2W100-115/230	Power Open Spring Return	3	6	115/230V AC	\$173.04
	2W104	Power Open Spring Return	3	6	24V AC	\$173.04
BELIMO	LF24	Power Open Spring Return	4	8	24V AC/DC	\$532.51
	LF24-S	Power Open Spring Return c/w Aux. Switch	4	8	24V AC/DC	\$723.06
	LF24-SR	Modulating Power Open Spring Close	4	8	24V AC/DC	\$730.27
	LF120	Power Open Spring Return	4	8	120V AC	\$557.23
	LF120-S	Power Open Spring Return c/w Aux. Switch	4	8	120V AC	\$558.26
	LF230	Power Open Spring Return	4	8	230V AC	\$603.58
	LF230-S	Power Open Spring Return c/w Aux. Switch	4	8	230V AC	\$855.93
	NF24	Power Open Spring Return	7.5	15	24V AC/DC	\$634.48
	NF24-S	Power Open Spring Return c/w Aux. Switch	7.5	15	24V AC/DC	\$730.27
	NF24-SR	Modulating Power Open Spring Close	7.5	15	24V AC/DC	\$837.39
	NF120	Power Open Spring Return	7.5	15	120V AC	\$717.91
	NF120-S	Power Open Spring Return c/w Aux. Switch	7.5	15	120V AC	\$818.85
	AF24	Power Open Spring Return	17.5	35	24V AC/DC	\$818.85
	AF24-S	Power Open Spring Return c/w Aux. Switch	17.5	35	24V AC/DC	\$921.85
	AF24-SR	Modulating Power Open Spring Close	17.5	35	24V AC/DC	\$1,032.06
	AF120	Power Open Spring Return	17.5	35	120V AC	\$903.31
	AF120-S	Power Open Spring Return c/w Aux. Switch	17.5	35	120V AC	\$1,079.44
	AF230	Power Open Spring Return	17.5	35	230V AC	\$1,014.55
AF230-S	Power Open Spring Return c/w Aux. Switch	17.5	35	230V AC	\$1,105.19	

For mounting of any actuator please add \$100 list Price

# MODEL FD - FIRE DAMPERS

		WIDTH (PARALLEL TO BLADES)													
		12	16	20	24	28	32	36	40	44	48	52	56	60	
HEIGHT	Inches	8	\$40.17	\$48.41	\$54.59	\$62.83	\$71.07	\$76.22	\$78.28	\$86.52	\$89.61	\$93.73	\$111.24	\$127.72	\$143.17
	10	\$46.35	\$54.59	\$62.83	\$64.89	\$76.22	\$78.28	\$84.46	\$89.61	\$93.73	\$97.85	\$113.30	\$129.78	\$146.26	
	12	\$48.41	\$59.74	\$64.89	\$66.95	\$78.28	\$81.37	\$86.52	\$93.73	\$97.85	\$105.06	\$121.54	\$138.02	\$154.50	
	16	\$56.65	\$64.89	\$71.07	\$78.28	\$86.52	\$91.67	\$93.73	\$103.00	\$111.24	\$115.36	\$133.90	\$154.50	\$169.95	
	20	\$62.83	\$71.07	\$78.28	\$89.61	\$93.73	\$100.94	\$108.15	\$113.30	\$124.63	\$129.78	\$151.41	\$169.95	\$189.52	
	24	\$64.89	\$78.28	\$91.67	\$93.73	\$105.06	\$111.24	\$119.48	\$127.72	\$133.90	\$143.17	\$165.83	\$187.46	\$206.00	
	28	\$73.13	\$84.46	\$93.73	\$105.06	\$111.24	\$127.72	\$141.11	\$149.35	\$156.56	\$169.95	\$189.52	\$206.00	\$223.51	
	32	\$78.28	\$89.61	\$100.94	\$111.24	\$124.63	\$143.17	\$158.62	\$173.04	\$184.37	\$194.67	\$211.15	\$223.51	\$243.08	
	36	\$81.37	\$93.73	\$105.06	\$115.36	\$133.90	\$158.62	\$180.25	\$194.67	\$208.06	\$221.45	\$234.84	\$245.14	\$261.62	
	40	\$86.52	\$97.85	\$111.24	\$124.63	\$143.17	\$173.04	\$194.67	\$208.06	\$221.45	\$234.84	\$252.35	\$264.71	\$281.19	
	44	\$91.67	\$105.06	\$473.80	\$129.78	\$156.56	\$184.37	\$187.46	\$221.45	\$234.84	\$252.35	\$267.80	\$283.25	\$297.67	
	48	\$97.85	\$111.24	\$127.72	\$141.11	\$167.89	\$194.67	\$221.45	\$234.84	\$252.35	\$264.71	\$283.25	\$299.73	\$317.24	
	52	\$111.24	\$124.63	\$143.17	\$156.56	\$187.46	\$211.15	\$238.96	\$252.35	\$267.80	\$283.25	\$299.73	\$319.30	\$337.84	
56	\$119.48	\$138.02	\$156.56	\$176.13	\$206.00	\$230.72	\$257.50	\$270.89	\$286.34	\$299.73	\$319.30	\$337.84	\$360.50		
60	\$127.72	\$151.41	\$173.04	\$196.73	\$221.45	\$249.26	\$276.04	\$288.40	\$305.91	\$321.36	\$341.96	\$360.50	\$382.13		

CATALOGUE #	DESCRIPTION	MAXIMUM SINGLE SELECTION	MAXIMUM MULTIPLE SELECTION	USE LIST
VA	Vertical "A"	60" x 60"	120" x 120" (4-60" x 60" Sections)	Use List
VB	Vertical "B"	60" x 54"	120" x 54" (3-60" x 54" Sections)	List x 1.2
HA	Horizontal "A"	40" x 40"	120" x 40" (3-40" x 40" Sections)	List x 1.2
HB	Horizontal "B"	40" x 36"	120" x 36" (4-40" x 36" Sections)	List x 1.4
RVC	Round Vertical "C"	35"	NA	List x 2
RHC	Round Horizontal "C"	35"	NA	List x 2.2

## CD ROUND CEILING DAMPERS

MODEL	DESCRIPTION	RATED	LIST PRICE
CD-RD-85	Round butterfly-type ceiling damper	3 - 4 Hours	SEE DUCT DIAMETER CHART BELOW
CD-RD-A-85	Round butterfly-type ceiling damper complete with adjustable controller	3 - 4 Hours	
CD-RD-T-86	Round butterfly-type ceiling damper complete with square-neck diffusers	3 - 4 Hours	
CD-RD-A/T-86	Same as above complete with adjustable controller	3 - 4 Hours	
FD	Fire blanket 24" x 24", 3-4 hour rated	3 - 4 Hours	\$78.28

DUCT DIAMETER	CD-RD-85	CD-RD-A-85	CD-RD-T-86	CD-RD-A/T-86
5"	\$64.89	\$143.17	\$84.46	\$162.74
6"	\$66.95	\$146.26	\$89.61	\$165.83
7"	\$73.13	\$149.35	\$91.67	\$169.95
8"	\$76.22	\$151.41	\$97.85	\$173.04
9"	\$78.28	\$154.50	\$100.94	\$178.19
10"	\$81.37	\$156.56	\$105.06	\$180.25
11"	\$84.46	\$158.62	\$108.15	\$187.46
12"	\$100.94	\$176.13	\$129.78	\$206.00
13"	\$108.15	\$184.37	\$141.11	\$216.30
14"	\$111.24	\$189.52	\$143.17	\$221.45
15"	\$121.54	\$196.73	\$156.56	\$232.78

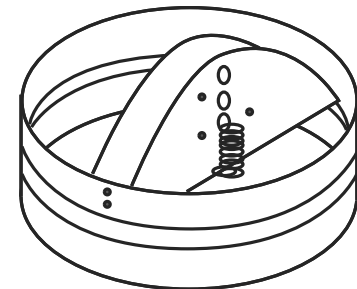

## AD - AF / ADI - AFI - ALUMINUM CONTROL DAMPERS

MODEL	DESCRIPTION	LIST PRICE	
AD	Duct Mount	\$84.46 Sq. Ft.	MIN. \$160.68
AF	Flange Mount	\$84.46 Sq. Ft.	MIN. \$160.68
ADI	Duct Mount Insulated	\$112.27 Sq. Ft.	MIN. \$214.24
AFI	Flange Mount Insulated	\$112.27 Sq. Ft.	MIN. \$214.24
Minimum size 2 Sq/ft Opposed Blade Standard			

**i** Non-standard dampers are non-returnable and cannot be cancelled.

# STEEL CONTROL DAMPERS -MODEL SCD / SCD-LL / SCD-HD-LL

HEIGHT	WIDTH									
	Inches	12	16	20	24	28	32	36	40	44
12	\$110.21	\$119.48	\$122.57	\$127.72	\$133.90	\$135.96	\$148.32	\$154.50	\$158.62	\$163.77
16	\$127.72	\$135.96	\$145.23	\$154.50	\$154.50	\$163.77	\$169.95	\$178.19	\$185.40	\$188.49
20	\$163.77	\$169.95	\$178.19	\$188.49	\$196.73	\$198.79	\$206.00	\$216.30	\$230.72	\$235.87
24	\$185.40	\$196.73	\$198.79	\$210.12	\$216.30	\$230.72	\$238.96	\$251.32	\$256.47	\$266.77
28	\$198.79	\$214.24	\$230.72	\$238.96	\$247.20	\$256.47	\$273.98	\$282.22	\$286.34	\$298.70
32	\$230.72	\$242.05	\$256.47	\$273.98	\$276.04	\$286.34	\$298.70	\$316.21	\$324.45	\$338.87
36	\$264.71	\$273.98	\$282.22	\$298.70	\$314.15	\$324.45	\$332.69	\$350.20	\$359.47	\$374.92
40	\$282.22	\$293.55	\$306.94	\$324.45	\$338.87	\$352.26	\$364.62	\$380.07	\$392.43	\$409.94
44	\$314.15	\$324.45	\$332.69	\$350.20	\$364.62	\$384.19	\$398.61	\$409.94	\$426.42	\$440.84
48	\$338.87	\$350.20	\$359.47	\$380.07	\$398.61	\$415.09	\$426.42	\$443.93	\$460.41	\$477.92
52	\$366.68	\$380.07	\$392.43	\$409.94	\$426.42	\$443.93	\$460.41	\$481.01	\$494.40	\$511.91
56	\$390.37	\$404.79	\$415.09	\$434.66	\$452.17	\$474.83	\$492.34	\$511.91	\$526.33	\$546.93
60	\$409.94	\$426.42	\$440.84	\$460.41	\$481.01	\$500.58	\$521.18	\$538.69	\$563.41	\$577.83
64	\$434.66	\$452.17	\$474.83	\$494.40	\$511.91	\$532.51	\$560.32	\$577.83	\$595.34	\$614.91
68	\$460.41	\$488.22	\$506.76	\$530.45	\$552.08	\$568.56	\$589.16	\$614.91	\$638.60	\$655.08
70	\$506.76	\$530.45	\$556.20	\$577.83	\$598.43	\$629.33	\$646.84	\$666.41	\$691.13	\$716.88

<b>SCD-LL</b>	Blade & Jamb Seals (Low Leakage)	List x 1.2
<b>SCD-HD-LL</b>	Heavy-Duty Construction( c/w Blade & Jamb Seals)	List x 1.7
<b>LQ</b>	Locking Quadrant	\$40.00
<b>For Actuators Add cost of Actuator and \$100 List Price for Installation</b>		

## MODEL SCD-RD-88

SCD-RD-88	
DIAMETER	LIST PRICE
5"	\$114.33
6"	\$117.42
7"	\$121.54
8"	\$123.60
9"	\$127.72
10"	\$133.90
12"	\$135.96
14"	\$143.17
16"	\$150.38
18"	\$157.59
20"	\$187.46
22"	\$244.11
24"	\$273.98

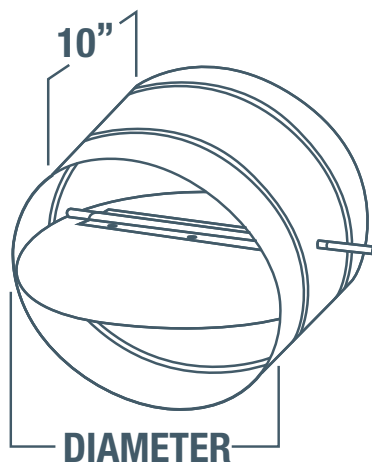

## MODEL SCD-RD-LL-88

SCD-RD-LL-88	
DIAMETER	LIST PRICE
6"	\$135.96
7"	\$139.05
8"	\$143.17
10"	\$146.26
12"	\$150.38
14"	\$157.59
16"	\$165.83
18"	\$172.01
20"	\$199.82
22"	\$257.50
24"	\$286.34



Non-standard dampers are non-returnable and cannot be cancelled.  
Please confirm your measurements and identify the series, width, height and blade type correctly.

# FIXED LOUVRES MODEL - EAL-6, EAL-6F

HEIGHT	WIDTH														
	Inches	16	20	24	28	32	36	40	44	48	52	56	60	64	68
16	\$157.59	\$190.55	\$215.27	\$249.26	\$278.10	\$304.88	\$335.78	\$364.62	\$396.55	\$425.39	\$450.11	\$482.04	\$510.88	\$539.72	\$569.59
20	\$197.76	\$233.81	\$273.98	\$304.88	\$344.02	\$382.13	\$417.15	\$454.23	\$493.37	\$527.36	\$565.47	\$597.40	\$635.51	\$673.62	\$707.61
24	\$238.96	\$280.16	\$325.48	\$369.77	\$410.97	\$804.43	\$501.61	\$544.87	\$590.19	\$633.45	\$673.62	\$716.88	\$764.26	\$804.43	\$847.69
28	\$251.32	\$294.58	\$341.96	\$382.13	\$425.39	\$472.77	\$512.94	\$560.32	\$601.52	\$644.78	\$692.16	\$735.42	\$781.77	\$822.97	\$866.23
32	\$289.43	\$341.96	\$390.37	\$443.93	\$493.37	\$547.96	\$597.40	\$650.96	\$700.40	\$748.81	\$802.37	\$851.81	\$905.37	\$953.78	\$1,009.40
36	\$325.48	\$385.22	\$445.99	\$504.70	\$565.47	\$618.00	\$679.80	\$737.48	\$799.28	\$856.96	\$912.58	\$972.32	\$1,034.12	\$1,087.68	\$1,148.45
40	\$341.96	\$400.67	\$461.44	\$516.03	\$576.80	\$635.51	\$692.16	\$748.81	\$811.64	\$868.29	\$930.09	\$988.80	\$1,046.48	\$1,105.19	\$1,166.99
44	\$380.07	\$445.99	\$512.94	\$576.80	\$644.78	\$707.61	\$776.62	\$845.63	\$907.43	\$974.38	\$1,038.24	\$1,105.19	\$1,171.11	\$1,236.00	\$1,307.07
48	\$390.37	\$461.44	\$522.21	\$590.19	\$658.17	\$726.15	\$786.92	\$856.96	\$925.97	\$988.80	\$1,056.78	\$1,123.73	\$1,187.59	\$1,254.54	\$1,320.46
52	\$429.51	\$504.70	\$576.80	\$653.02	\$726.15	\$799.28	\$872.41	\$948.63	\$1,019.70	\$1,094.89	\$1,166.99	\$1,242.18	\$1,316.34	\$1,391.53	\$1,461.57
56	\$472.77	\$552.08	\$633.45	\$714.82	\$793.10	\$872.41	\$953.78	\$1,036.18	\$1,117.55	\$1,202.01	\$1,279.26	\$1,359.60	\$1,440.97	\$1,522.34	\$1,603.71
60	\$482.04	\$565.47	\$644.78	\$726.15	\$804.43	\$886.83	\$972.32	\$1,053.69	\$1,130.94	\$1,213.34	\$1,291.62	\$1,374.02	\$1,458.48	\$1,539.85	\$1,619.16
64	\$522.21	\$612.85	\$696.28	\$784.86	\$872.41	\$963.05	\$1,053.69	\$1,140.21	\$1,230.85	\$1,316.34	\$1,405.95	\$1,496.59	\$1,580.02	\$1,671.69	\$1,759.24
68	\$531.48	\$613.88	\$707.61	\$799.28	\$886.83	\$974.38	\$1,063.99	\$1,150.51	\$1,242.18	\$1,332.82	\$1,420.37	\$1,507.92	\$1,598.56	\$1,689.20	\$1,775.72
72	\$574.74	\$664.35	\$764.26	\$864.17	\$953.78	\$1,053.69	\$1,148.45	\$1,248.36	\$1,339.00	\$1,438.91	\$1,533.67	\$1,628.43	\$1,723.19	\$1,823.10	\$1,915.80

Note: For Larger sizes, use \$46/SQ FT - Minimum size is 6"x16"

## OPTIONS

OPTIONS	LIST PRICE
Insect Screen Factory Installed	\$9.00/Sq. Ft. Minimum \$74.16
Bird Screen Factory Installed	INCLUDED
Baked Enamel	\$10.00/Sq. Ft. Minimum \$432.60
Special Coatings	CALL FOR DETAILS

# OPERATING LOUVRES MODEL - EAL-4-0, EAL-4-OF

HEIGHT	WIDTH												
	Inches	12	16	20	24	28	32	36	40	44	48	52	56
12	\$145.23	\$177.16	\$203.94	\$238.96	\$278.10	\$312.09	\$346.08	\$373.89	\$404.79	\$443.93	\$478.95	\$516.03	\$552.08
16	\$177.16	\$215.27	\$261.62	\$300.76	\$346.08	\$396.55	\$431.57	\$478.95	\$527.36	\$563.41	\$612.85	\$658.17	\$692.16
20	\$597.40	\$261.62	\$323.42	\$373.89	\$420.24	\$478.95	\$527.36	\$586.07	\$635.51	\$692.16	\$741.60	\$802.37	\$847.69
24	\$253.38	\$312.09	\$373.89	\$431.57	\$501.61	\$563.41	\$621.09	\$692.16	\$756.02	\$811.64	\$872.41	\$945.54	\$1,003.22
28	\$289.43	\$359.47	\$431.57	\$501.61	\$574.74	\$644.78	\$716.88	\$786.92	\$861.08	\$930.09	\$1,003.22	\$1,074.29	\$1,158.75
32	\$323.42	\$404.79	\$490.28	\$574.74	\$644.78	\$728.21	\$811.64	\$895.07	\$976.44	\$1,060.90	\$1,146.39	\$1,215.40	\$1,299.86
36	\$335.78	\$420.24	\$501.61	\$586.07	\$671.56	\$756.02	\$834.30	\$917.73	\$1,003.22	\$1,087.68	\$1,158.75	\$1,242.18	\$1,327.67
40	\$373.89	\$466.59	\$563.41	\$658.17	\$741.60	\$834.30	\$930.09	\$1,015.58	\$1,110.34	\$1,246.30	\$1,299.86	\$1,382.26	\$1,479.08
44	\$420.24	\$516.03	\$621.09	\$682.89	\$825.03	\$917.73	\$1,025.88	\$1,123.73	\$1,230.85	\$1,327.67	\$1,430.67	\$1,526.46	\$1,633.58
48	\$454.23	\$563.41	\$671.56	\$786.92	\$895.07	\$1,003.22	\$1,123.73	\$1,230.85	\$1,336.94	\$1,456.42	\$1,563.54	\$1,671.69	\$1,779.84
52	\$490.28	\$612.85	\$728.21	\$847.69	\$969.23	\$1,087.68	\$1,215.40	\$1,336.94	\$1,456.42	\$1,574.87	\$1,694.35	\$1,813.83	\$1,931.25
56	\$527.36	\$658.17	\$786.92	\$917.73	\$1,049.57	\$1,185.53	\$1,299.86	\$1,430.67	\$1,563.54	\$1,694.35	\$1,825.16	\$1,953.91	\$2,087.81
60	\$563.41	\$705.55	\$847.69	\$976.44	\$1,123.73	\$1,261.75	\$1,397.71	\$1,539.85	\$1,683.02	\$1,813.83	\$1,953.91	\$2,097.08	\$2,243.34

Note: For Larger sizes, use \$46/SQ FT - Minimum size is 6"x16"

## OPTIONS

OPTIONS	LIST PRICE
Insect Screen Factory Installed (Includes sleeve)	\$9.00/Linear Ft. Minimum \$190.55
Bird Screen Factory Installed	INCLUDED
Baked Enamel	\$10.00/Sq. Ft. Minimum \$432.60
Special Coatings	CALL FOR DETAILS
Damper Actuators - See page 34 of price book for more details	-



Non-standard shutters are non-returnable and cannot be cancelled.  
Please confirm your measurements and identify the series, width, height and blade type correctly.

# FIXED LOUVRES MODEL - EAL-2, EAL-2F

		WIDTH															
		12	16	20	24	28	32	36	40	44	48	52	56	60	64	68	72
HEIGHT	12	\$69.01	\$87.55	\$101.97	\$120.51	\$136.99	\$153.47	\$172.01	\$190.55	\$203.94	\$220.42	\$238.96	\$257.50	\$273.98	\$294.58	\$312.09	\$325.48
	16	\$87.55	\$110.21	\$130.81	\$153.47	\$174.07	\$197.76	\$220.42	\$241.02	\$261.62	\$284.28	\$312.09	\$332.69	\$353.29	\$375.95	\$396.55	\$420.24
	20	\$108.15	\$130.81	\$163.77	\$190.55	\$215.27	\$241.02	\$268.83	\$298.70	\$323.42	\$346.08	\$380.07	\$402.73	\$429.51	\$461.44	\$484.10	\$510.88
	24	\$120.51	\$149.35	\$177.16	\$210.12	\$238.96	\$268.83	\$298.70	\$325.48	\$359.47	\$385.22	\$417.15	\$445.99	\$474.83	\$504.70	\$533.54	\$565.47
	28	\$143.17	\$174.07	\$210.12	\$241.02	\$278.10	\$312.09	\$346.08	\$382.13	\$417.15	\$450.11	\$484.10	\$522.21	\$561.03	\$586.07	\$618.00	\$658.17
	32	\$153.47	\$192.61	\$228.66	\$261.62	\$300.76	\$341.96	\$375.95	\$410.97	\$450.11	\$484.10	\$522.21	\$560.32	\$597.40	\$633.45	\$671.56	\$707.61
	36	\$172.01	\$213.21	\$257.50	\$298.70	\$341.96	\$382.13	\$425.39	\$466.59	\$510.88	\$547.96	\$590.19	\$633.45	\$673.62	\$716.88	\$761.17	\$802.37
	40	\$192.61	\$238.96	\$284.28	\$332.69	\$380.07	\$425.39	\$472.77	\$516.03	\$565.47	\$612.85	\$658.17	\$707.61	\$756.02	\$802.37	\$847.69	\$895.07
	44	\$203.94	\$257.50	\$300.76	\$353.29	\$402.73	\$450.11	\$501.61	\$552.08	\$597.40	\$650.96	\$700.40	\$746.75	\$799.28	\$847.69	\$895.07	\$948.63
	48	\$228.66	\$280.16	\$332.69	\$385.22	\$443.93	\$495.43	\$552.08	\$601.52	\$658.17	\$714.82	\$766.32	\$822.97	\$872.41	\$930.09	\$982.62	\$1,038.24
	52	\$238.96	\$294.58	\$353.29	\$408.91	\$466.59	\$522.21	\$576.80	\$635.51	\$692.16	\$748.81	\$804.43	\$864.17	\$917.73	\$974.38	\$1,036.18	\$1,087.68
	56	\$259.56	\$318.27	\$382.13	\$443.93	\$504.70	\$565.47	\$630.36	\$684.95	\$748.81	\$813.70	\$872.41	\$936.27	\$997.04	\$1,058.84	\$1,120.64	\$1,185.53
	60	\$278.10	\$344.02	\$410.97	\$474.83	\$544.87	\$612.85	\$673.62	\$743.66	\$811.64	\$877.56	\$942.45	\$1,009.40	\$1,077.38	\$1,140.21	\$1,208.19	\$1,275.14
	64	\$289.43	\$361.53	\$429.51	\$495.43	\$569.59	\$635.51	\$703.49	\$770.44	\$845.63	\$912.58	\$979.53	\$1,053.69	\$1,120.64	\$1,187.59	\$1,256.60	\$1,327.67
	68	\$312.09	\$382.13	\$461.44	\$531.48	\$606.67	\$679.80	\$756.02	\$828.12	\$905.37	\$974.38	\$1,053.69	\$1,123.73	\$1,202.01	\$1,272.05	\$1,344.15	\$1,420.37
72	\$323.42	\$400.67	\$474.83	\$552.08	\$630.36	\$703.49	\$781.77	\$864.17	\$936.27	\$1,015.58	\$1,087.68	\$1,166.99	\$1,242.18	\$1,318.40	\$1,395.65	\$1,488.35	

Note: For Larger sizes, use \$38/SQ FT - Minimum size is 6"x 6"

# FIXED LOUVRES MODEL - EAL-4, EAL-4F

		WIDTH															
		12	16	20	24	28	32	36	40	44	48	52	56	60	64	68	72
HEIGHT	12	\$87.55	\$108.15	\$112.27	\$128.75	\$149.35	\$166.86	\$187.46	\$197.76	\$215.27	\$235.87	\$289.43	\$292.52	\$294.58	\$312.09	\$323.42	\$344.02
	16	\$108.15	\$112.27	\$143.17	\$160.68	\$187.46	\$233.81	\$245.14	\$257.50	\$312.09	\$335.78	\$361.53	\$369.77	\$385.22	\$436.72	\$463.50	\$501.61
	20	\$128.75	\$143.17	\$190.55	\$220.42	\$224.54	\$257.50	\$312.09	\$341.96	\$369.77	\$402.73	\$431.57	\$463.50	\$493.37	\$522.21	\$556.20	\$586.07
	24	\$136.99	\$166.86	\$197.76	\$230.72	\$259.56	\$289.43	\$323.42	\$353.29	\$382.13	\$410.97	\$445.99	\$474.83	\$504.70	\$533.54	\$569.59	\$597.40
	28	\$157.59	\$194.67	\$230.72	\$268.83	\$300.76	\$335.78	\$375.95	\$408.91	\$445.99	\$482.04	\$512.94	\$552.08	\$586.07	\$624.18	\$658.17	\$696.28
	32	\$184.37	\$220.42	\$261.62	\$300.76	\$344.02	\$382.13	\$425.39	\$466.59	\$504.70	\$547.96	\$586.07	\$630.36	\$671.56	\$707.61	\$748.81	\$786.92
	36	\$203.94	\$249.26	\$294.58	\$341.96	\$385.22	\$429.51	\$474.83	\$522.21	\$569.59	\$612.85	\$658.17	\$703.49	\$748.81	\$799.28	\$840.48	\$886.83
	40	\$228.66	\$278.10	\$325.48	\$380.07	\$429.51	\$474.83	\$527.36	\$576.80	\$630.36	\$679.80	\$728.21	\$781.77	\$831.21	\$884.77	\$933.18	\$982.62
	44	\$249.26	\$300.76	\$359.47	\$410.97	\$466.59	\$522.21	\$580.92	\$635.51	\$692.16	\$746.75	\$802.37	\$856.96	\$912.58	\$969.23	\$1,019.70	\$1,082.53
	48	\$257.50	\$312.09	\$364.62	\$425.39	\$482.04	\$533.54	\$590.19	\$644.78	\$700.40	\$761.17	\$813.70	\$868.29	\$925.97	\$979.53	\$1,038.24	\$1,094.89
	52	\$278.10	\$341.96	\$400.67	\$461.44	\$522.21	\$580.92	\$641.69	\$703.49	\$764.26	\$822.97	\$886.83	\$948.63	\$1,003.22	\$1,067.08	\$1,127.85	\$1,187.59
	56	\$298.70	\$364.62	\$429.51	\$495.43	\$560.32	\$630.36	\$696.28	\$761.17	\$828.12	\$888.89	\$958.93	\$1,019.70	\$1,087.68	\$1,150.51	\$1,222.61	\$1,287.50
	60	\$323.42	\$390.37	\$463.50	\$533.54	\$601.52	\$673.62	\$746.75	\$813.70	\$886.83	\$958.93	\$1,034.12	\$1,100.04	\$1,169.05	\$1,242.18	\$1,310.16	\$1,382.26
	64	\$344.02	\$420.24	\$493.37	\$575.95	\$644.78	\$721.00	\$799.28	\$872.41	\$950.69	\$1,025.88	\$1,100.04	\$1,171.11	\$1,251.45	\$1,327.67	\$1,402.86	\$1,479.08
	68	\$353.29	\$429.51	\$504.70	\$580.92	\$658.17	\$735.42	\$804.43	\$884.77	\$958.93	\$1,036.18	\$1,110.34	\$1,187.59	\$1,261.75	\$1,339.00	\$1,418.31	\$1,490.41
72	\$375.95	\$454.23	\$533.54	\$614.91	\$696.28	\$781.77	\$864.17	\$942.45	\$1,019.70	\$1,103.13	\$1,185.53	\$1,261.75	\$1,344.15	\$1,423.46	\$1,505.86	\$1,590.32	

Note: For Larger sizes, use \$41/SQ FT - Minimum size is 6"x 12"

## OPTIONS

OPTIONS	LIST PRICE
Insect Screen Factory Installed	\$9.00/Sq. Ft. Minimum \$74.16
Baked Enamel	\$10.00/Sq. Ft. Minimum \$432.60
Special Coatings	CALL FOR DETAILS

## PENTHOUSES

PENTHOUSES	LIST PRICE
EAP-4M Mitered corner Penthouse (per square foot of penthouse face area)	CALL FOR DETAILS
EAP-4 Box corner Penthouse (per square foot of penthouse face area)	CALL FOR DETAILS



Non-standard shutters are non-returnable and cannot be cancelled.  
Please confirm your measurements and identify the series, width, height and blade type correctly.